

ROCKY MOUNTAIN

H A R D W A R E

Element Dummy - Lever to Lever

- 1 Lever
- 2 Escutcheon
- 3 Plug
- 4 Face Plate
- 5 Lever Set Screw
- 6 Spindle
- 7 Plug Screw
- 8 Face Plate Screw
- 9 Plug Set Screw

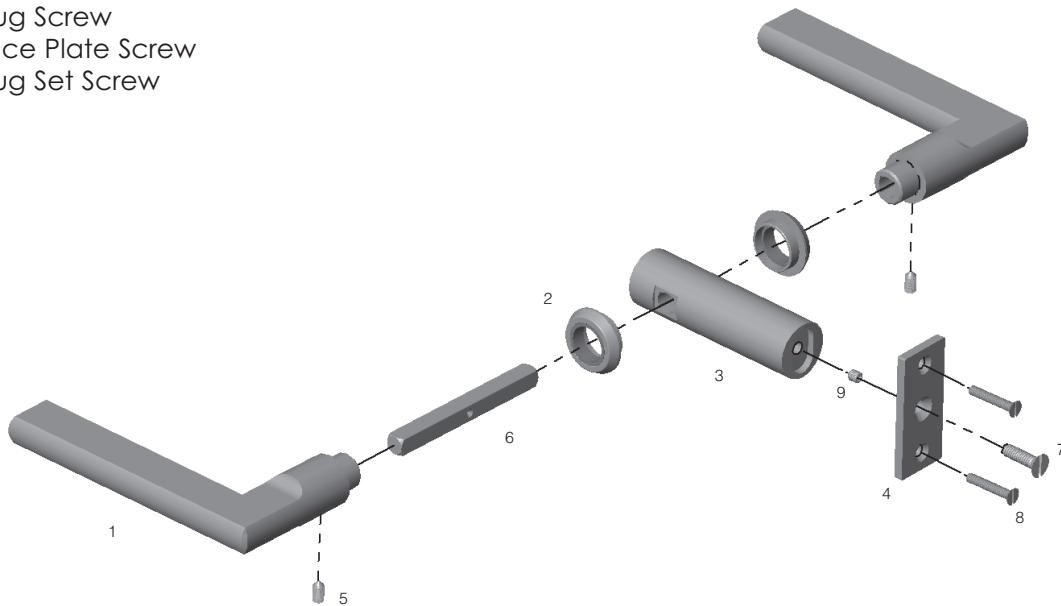

ROCKY MOUNTAIN

H A R D W A R E

ELEMENT COLLECTION - DOOR PREPARATORY SPECIFICATIONS

Dummy Lever to Lever - Interior & Exterior

Not Applicable for Double Door situations, Edge, or Bluetooth Options

Notes:

1. This bore specification is applicable for 2 1/2" or 2 3/4" backsets.
2. Half dummy application, bore one side only.
3. Standard location of hardware is determined by placing the lever or knob 36" above finish floor. However, this may be adjusted for special applications.

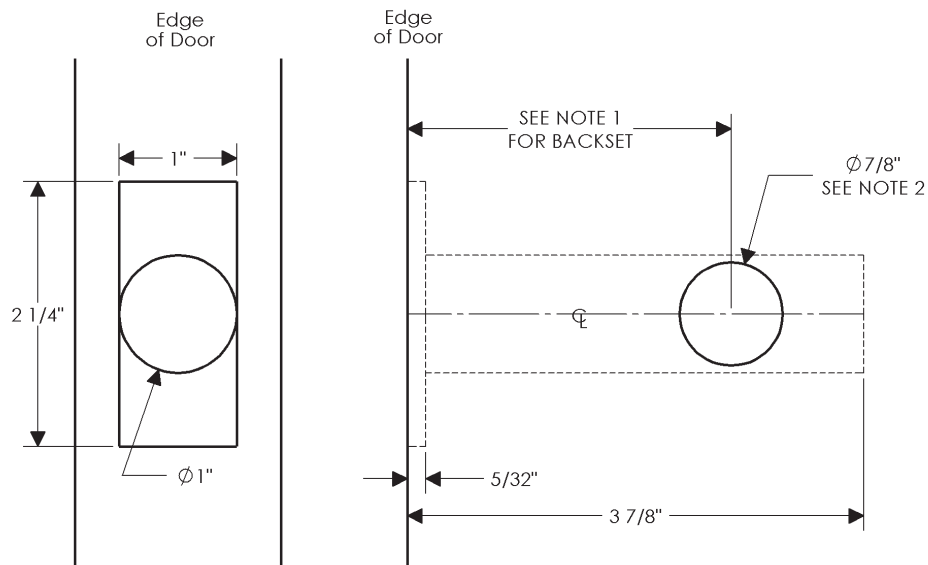



Element Dummy Installation Instructions

1. Mark the Door

The standard location of the of the lever or knob at 36" above the finished floor. **However, this may be adjusted for special applications. Layout the escutcheon on the door before boring to confirm it is placed at the appropriate height for the size of the escutcheon/door.**

2. Compare Lock, Hardware Trim and Door Conditions

Verify that the stile width is adequate to accept the plug and hardware trim. Make sure the hardware trim does not interfere with the door stop or the astragal and does not overlap the door panel or glass.

3. Plug Cavity

Refer to the Door Preparatory Specifications sheets for the specific dimensions of the cavity. Mortise the cavity.

4. Mortising Face Plate

Refer to the Door Preparatory Specifications sheets for the specific dimensions of the Face Plate. Mortise the edge of the door for the Face Plate.

5. Mark Face of Door

Use the Door Preparatory Specifications sheets to determine the appropriate size and locations of the holes on the face of the door for the lock and hardware trim. Please note the correct backset.

6. Drill Holes

Verify all dimensions and locations from Step 6, then drill the holes.

7. Lever/ Knob Trim

Install plug in edge of door. Install the spindle through the plug and center on door. Tighten plug set screw. Install face plate. Install levers with escutcheon and washer onto spindles. With the lever tight to the door, tighten set screws.

General Notes

1. This door preparatory specification is not applicable to double door situations with opposing active panels.
2. Make sure all door conditions are compatible with the plug and trim before drilling or mortising the door. If there are any issues with the plug or trim, please contact the Distributor that provided the hardware immediately.
3. Hardware should be removed from door before painting or finishing of the door. Allow finish to fully cure before reinstalling hardware. Refer to paint manufacturer for instructions and curing times.