



ELEMENT COLLECTION - DOOR PREPARATORY SPECIFICATIONS

Bluetooth Entry Mortise Lock Lever to Lever - Interior

Notes:

1. This bore specification is applicable for 2 1/2" or 2 3/4" backset mortise locks.
2. Standard location of mortise lock is determined by placing the lever or knob 36" above finish floor. However, this may be adjusted for special applications.
3. 1 3/4" minimum door thickness.

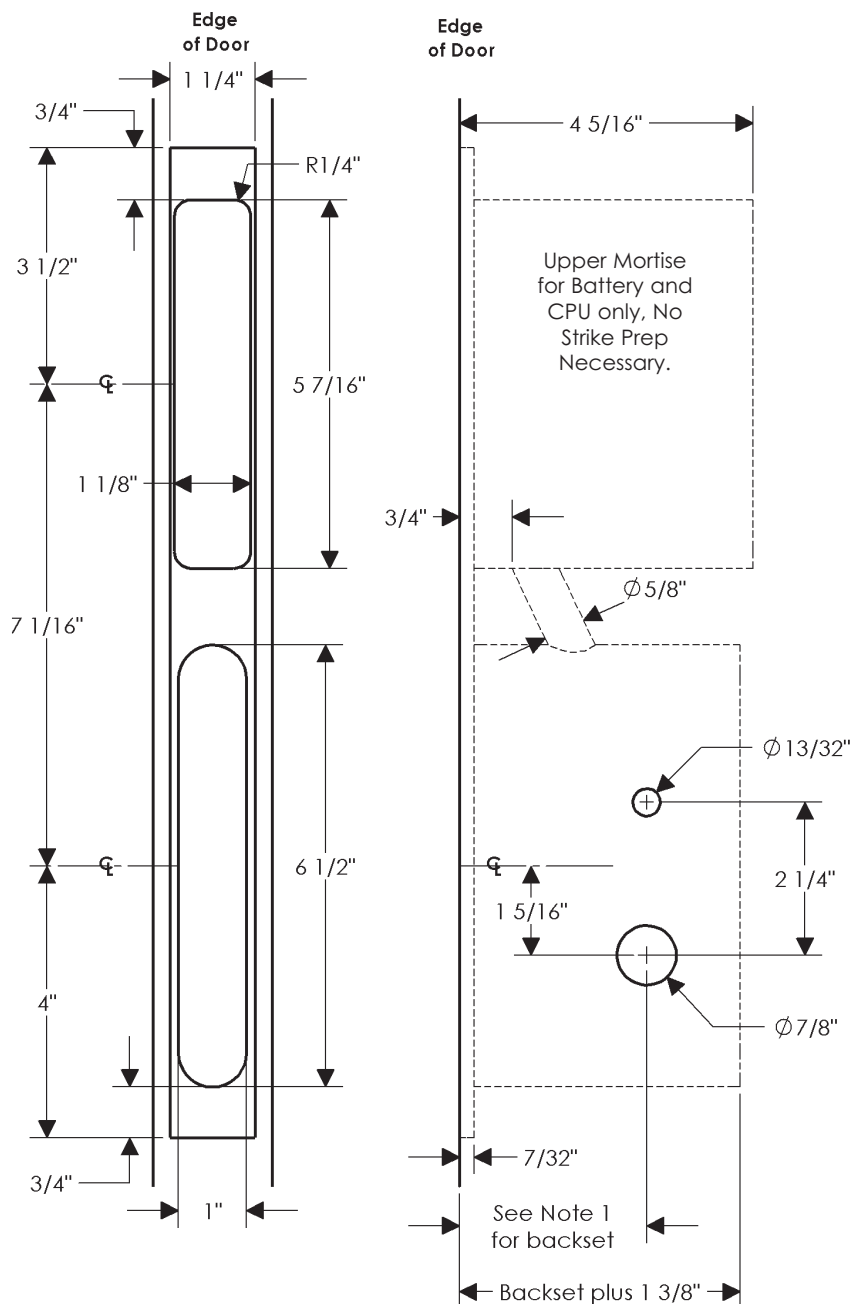



ELEMENT COLLECTION - DOOR PREPARATORY SPECIFICATIONS

Bluetooth Entry Mortise Lock Lever to Lever - Exterior

Notes:

1. This bore specification is applicable for 2 1/2" or 2 3/4" backset mortise locks.
2. Standard location of mortise lock is determined by placing the lever or knob 36" above finish floor. However, this may be adjusted for special applications.
3. 1 3/4" minimum door thickness.

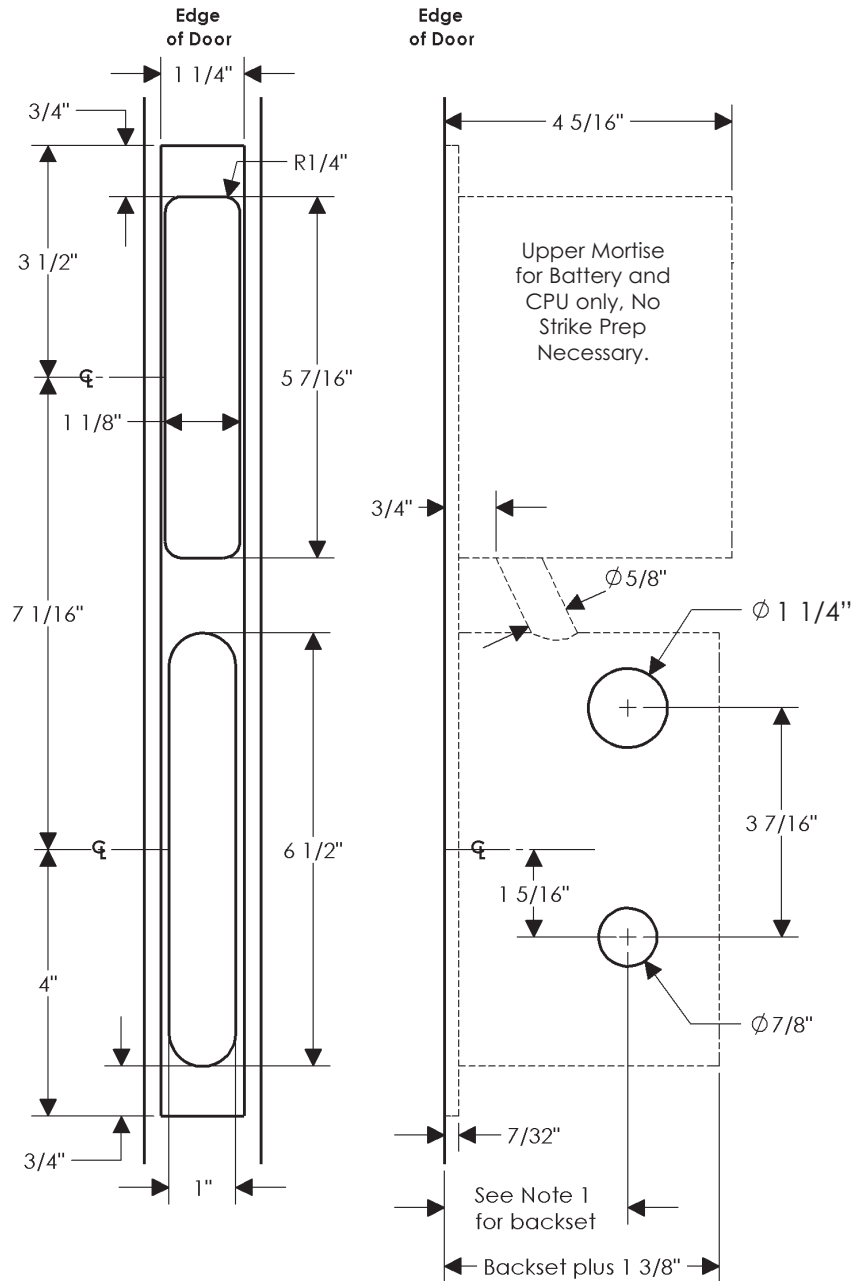



ELEMENT COLLECTION - DOOR PREPARATORY SPECIFICATIONS

Strike - Mortise Lock

Notes:

1. This dimension is 1/2 of door thickness, eg., 1 3/4" divided by 2 = 7/8". This dimension will have to be adjusted for different door thicknesses and unusual jamb or door conditions.

