

Entry Mortise Lock—Interior

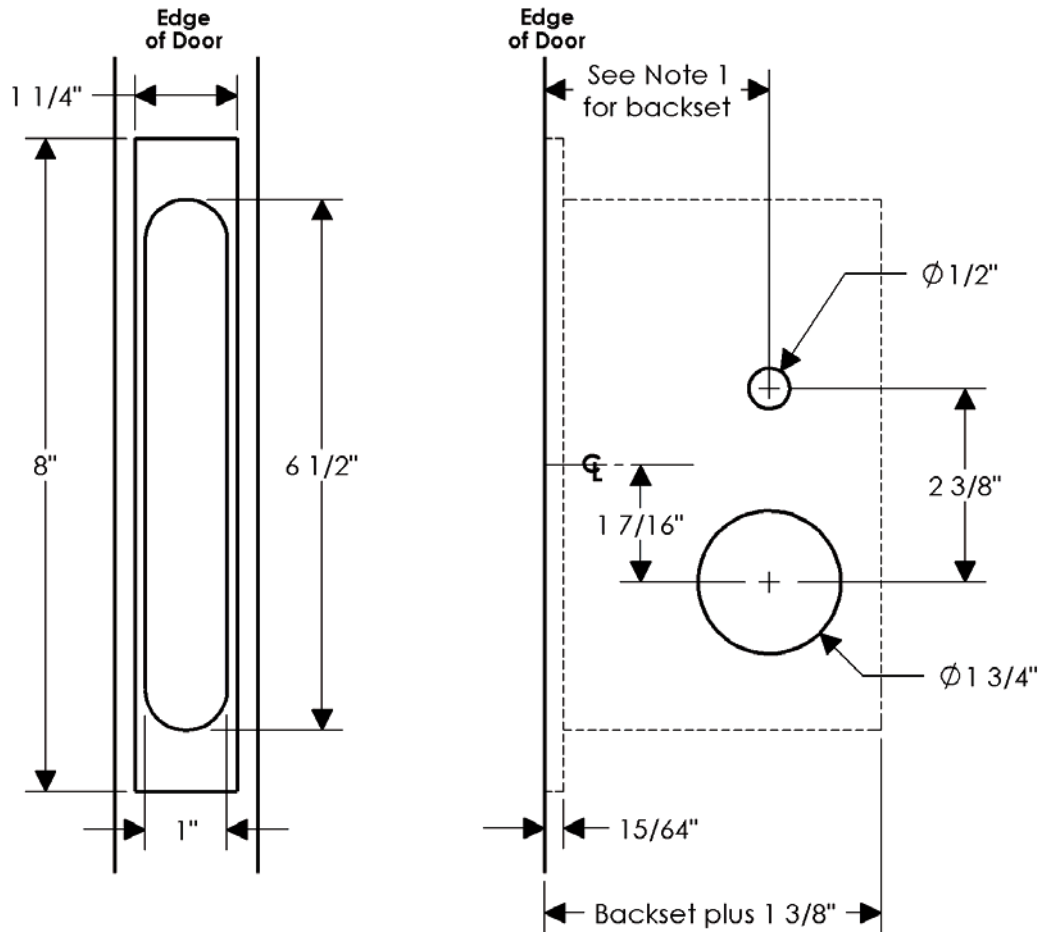

Notes:

1. This bore specification is applicable for 2 1/2" or 2 3/4" backset mortise locks.
2. Standard location of mortise lock is determined by placing the lever or knob 36" above finish floor. However, this may be adjusted for special applications.
3. 1 3/4" minimum door thickness.

Entry Mortise Lock—Exterior

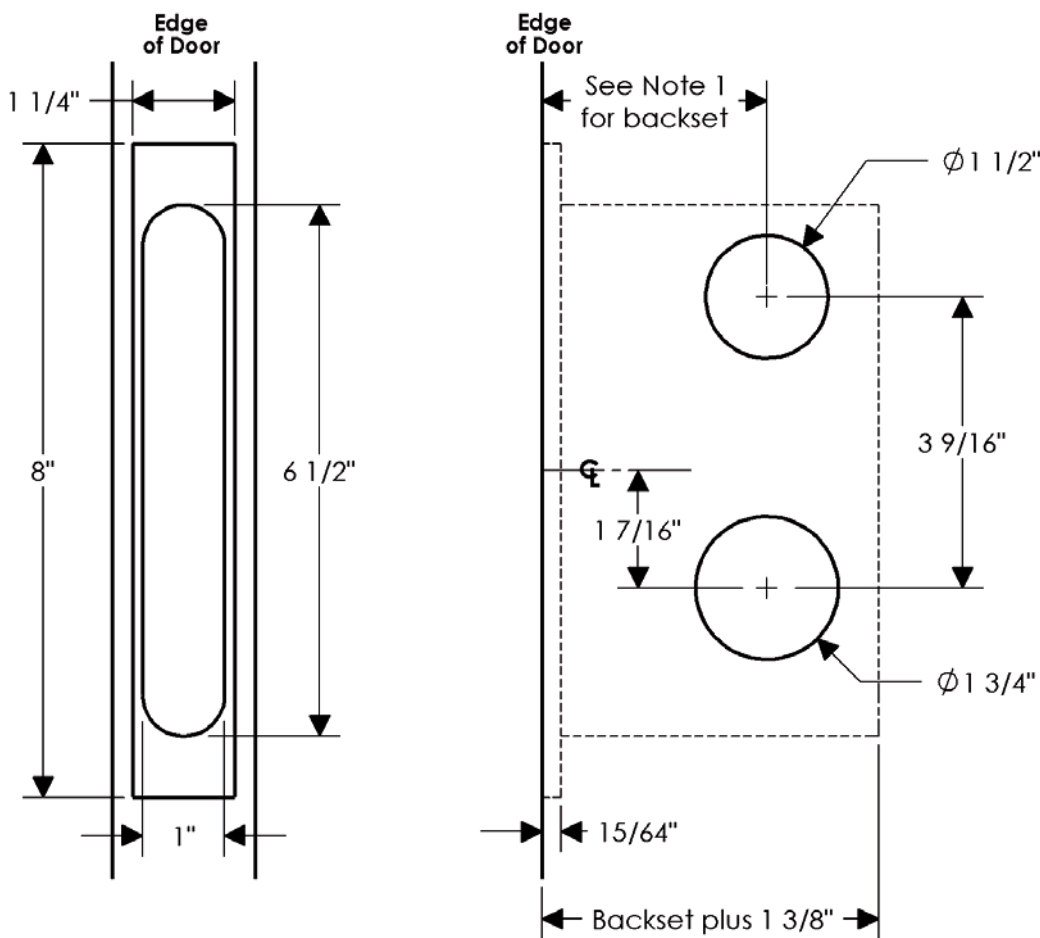

Notes:

1. This bore specification is applicable for 2 1/2" or 2 3/4" backset mortise locks.
2. Standard location of mortise lock is determined by placing the lever or knob 36" above finish floor. However, this may be adjusted for special applications.
3. 1 3/4" minimum door thickness.